

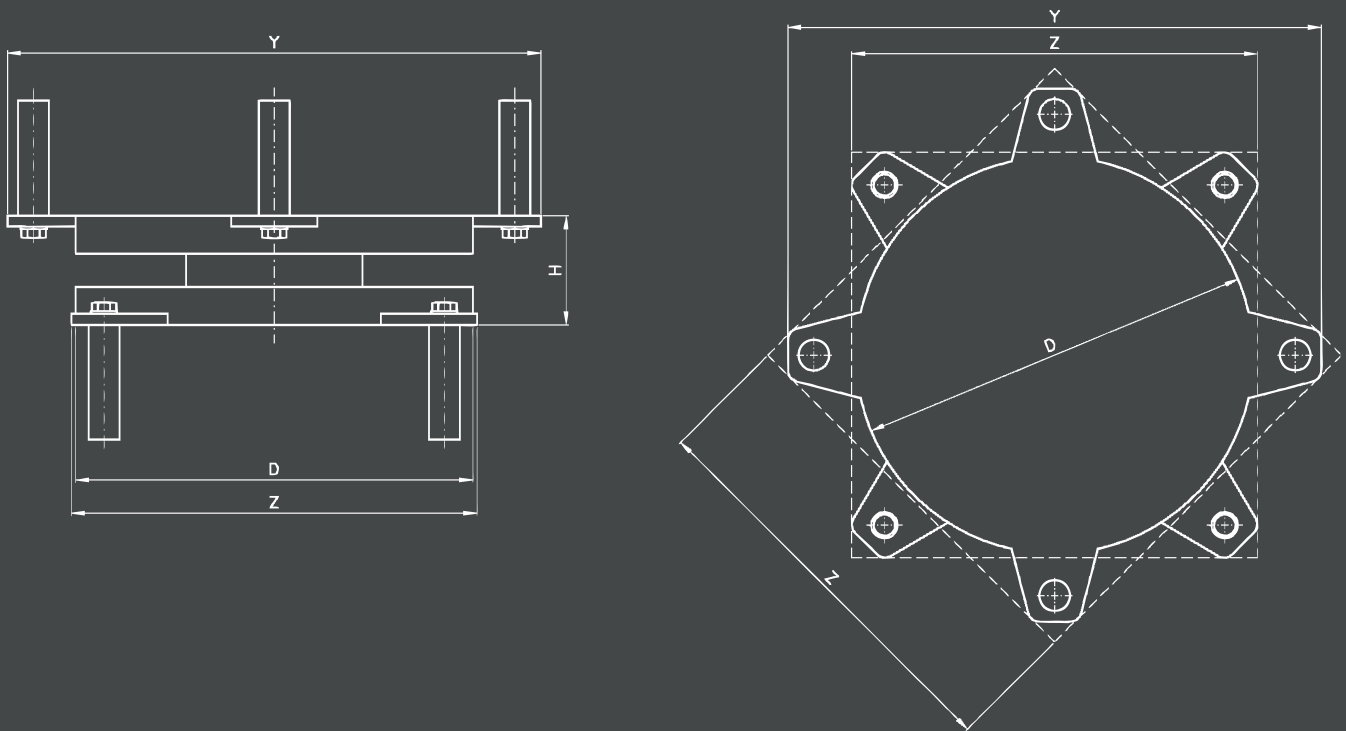

FIPMEC

CURVED SURFACE SLIDERS

SCHEME FIP-D



Schematic drawing for FIP-D isolator with four upper/lower dowels

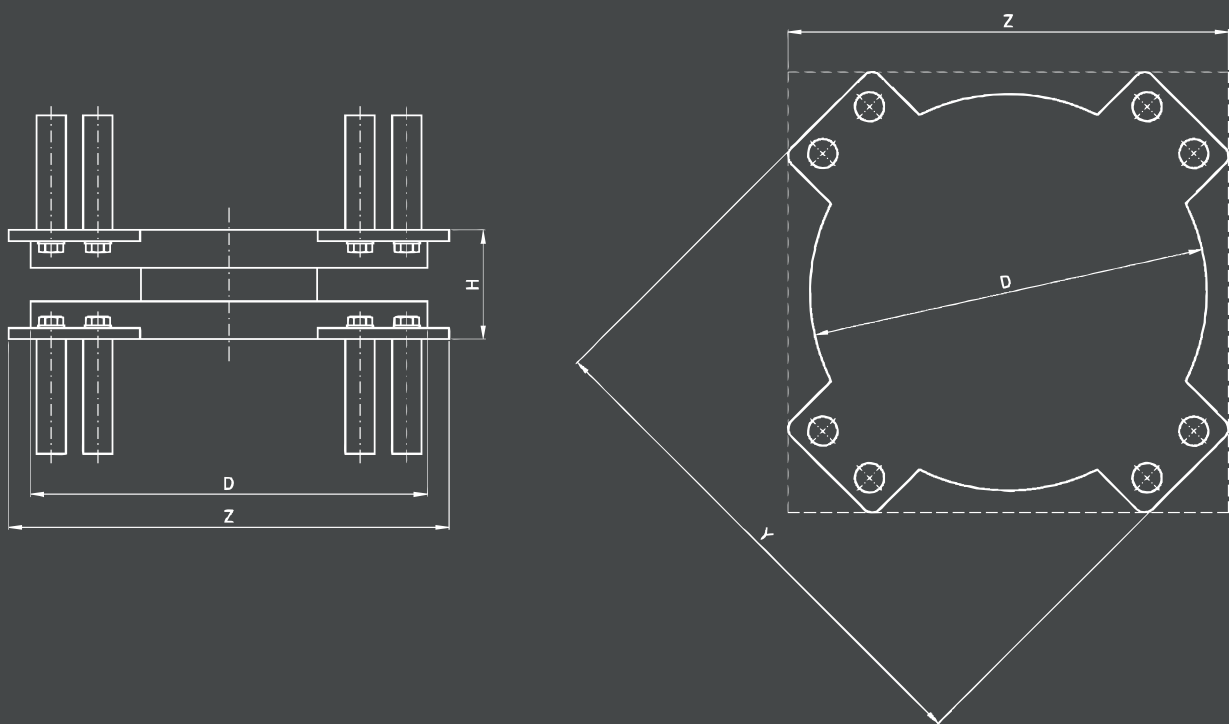

Schematic drawing for FIP-D isolator with eight or more upper/lower dowels



• CASTEL DI SANGRO, ITALY - private building

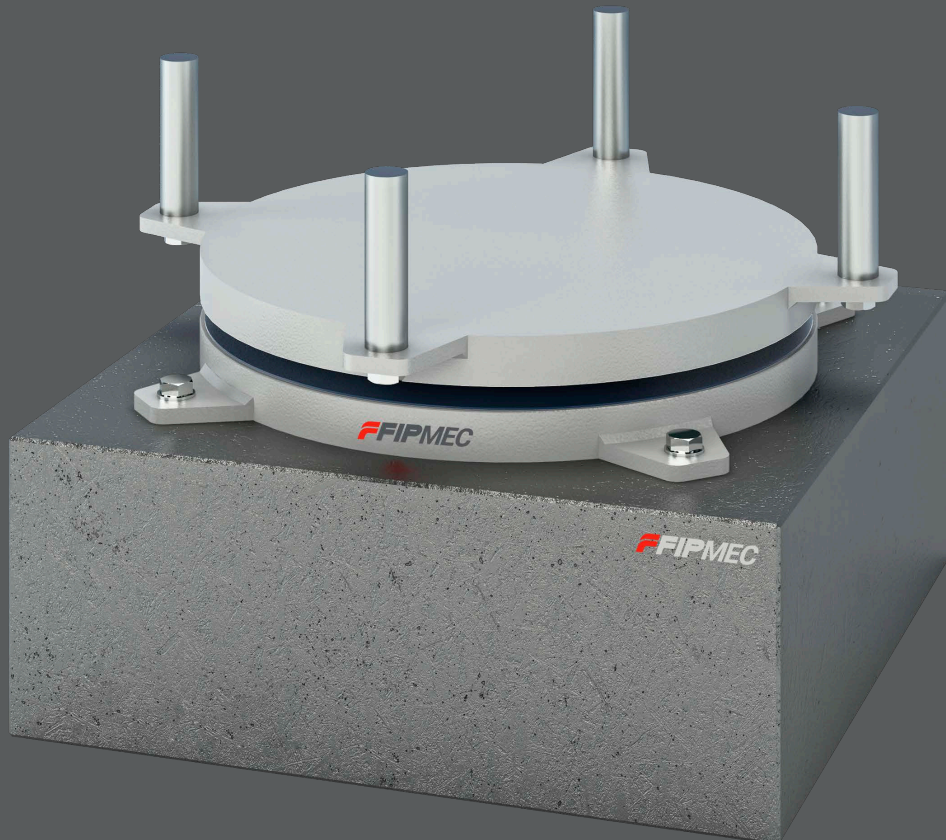

INTRODUCTION

CERTIFICATIONS

In the framework of the enforcement of the European Construction Products Directive, **FIP MEC** has gained the CE marking of different types of anti-seismic devices, including curved surface sliders, in accordance with the harmonised European Standard EN 15129:2009 *Anti-seismic devices*.



BIM READY

The use of shared digital representations to facilitate the design, construction and operation of a structure is the starting point for a reliable and interactive decision-making process which allows municipalities, private clients, contractors and designers to rule all their choices.

FIP MEC is able to provide BIM models – according to IFC standard – to its Clients in such a way to support the communication, cooperation, simulation and improvement of a project through the whole design life of the built or building structure.

DESCRIPTION

The curved surface sliders or **Friction Isolation Pendula (FIP)** are sliding isolators based on the working principle of the simple pendulum. In a structure that is isolated by means of curved surface sliders, the period of oscillation mainly depends on the radius of curvature of the curved sliding surface, i.e. it is almost independent from the mass of the structure. The energy dissipation is provided by the friction encountered during the movement of the sliding surfaces, and the re-centring capability is provided by the curvature of the sliding surface.

The **Friction Isolation Pendulum** can be designed and manufactured in two main types, with one or two primary spherical sliding surfaces that accommodate the horizontal displacement, respectively classified as **FIP** or **+FIP-D** series as follows.

The **FIP** series devices are characterised by: **i)** a concave slider (top element in the picture) whose radius of curvature imposes the period of oscillation and that accommodates for the horizontal displacement; **ii)** a base element with a secondary concave sliding surface that permits the rotation; **iii)** a steel intermediate element with two convex surfaces suitably shaped to be coupled with the other two elements. The device can also be installed upside-down, i.e. with the main concave slider at the bottom.

The **FIP-D** series or double concave curved surface sliders are characterised by two primary concave sliding surfaces with the same radius of curvature; both surfaces accommodate for horizontal displacement and rotation. In this case each single sliding surface is designed to accommodate only half of the total horizontal displacement, so that the dimensions in plan of the devices may be significantly smaller in comparison with **FIP** series. Another advantage of **FIP-D** series versus **FIP** series is that the eccentricity of the vertical load (**P-Δ** effect) is halved, i.e. is equal to half the displacement, while in **FIP** series devices it is equal to the displacement (on one side).



CHARACTERISTICS

MATERIALS

The selection of the sliding material is essential to give the curved surface sliders an optimal behaviour in terms of: i) load bearing capacity; ii) friction coefficient and consequently energy dissipation; iii) stability of the hysteretic force vs. displacement curve both with cycling and with temperature; iv) durability; v) wear resistance.

The sliding material utilized in the primary sliding surfaces is the **FFM (FIP Friction Material)**, an Ultra-High Molecular Weight Poly-Ethylene (UHMW-PE) characterised by exceptional properties in terms of load bearing capacity, wear resistance, as well as stability and durability. Other important characteristics of **FFM** are the absence of stick-slip and the low value of the ratio between the break-away and the dynamic friction coefficients.

The above properties have been verified through extensive testing campaigns, including among others all the tests required by the European Standard EN 15129, carried out both in **FIP MEC** laboratory and in independent laboratories.

FFM is used without lubrication. The material used in the secondary sliding surface of **FIP** series devices is a dimpled and lubricated UHMW-PE.

The dynamic friction coefficient is the most important parameter that the Structural Engineer needs to know when modelling a structure with curved surface sliders. For any sliding material the friction coefficient is dependent on both velocity and pressure. However, the dependence on velocity is not significant in the range of velocity associated with earthquake excitation of an isolated structure. Conversely, it is well known from literature, and confirmed by test results, that the dependence on pressure (vertical load) is not negligible; in particular, the friction coefficient decreases at the increasing of the vertical load.

Typical values of dynamic friction coefficient of **FFM** are reported in the table, respectively for **FFM** type L (Low friction) and **FFM** type M (Medium friction).

FFM type	L (low friction)	M (medium friction)
Minimum friction coefficient (%)	2.5	5.5

The above values of the friction coefficient are minimum values and correspond to the maximum design vertical load N_{Ed} of the curved surface slider, i.e. the maximum vertical load at ULS load combinations including the seismic action, or at any load combination including horizontal displacement. For the standard **FIP-D** isolators, the values of the maximum design vertical load N_{Ed} are reported in the tables at the end of this catalogue.

On request, different values of friction coefficient can be provided. Austenitic steel in accordance with the European Standard EN 10088-2 is commonly used as mating surface.



MODELLING

The mathematical model that best resembles the functioning of the curved surface sliders (both **FIP** and **FIP-D** series) consists of a bilinear force-displacement curve as shown in the figure, where:

$$F_0 = \mu \cdot N_{Sd} \rightarrow \text{friction force developed by the isolator}$$

$$F_{max} = F_0 + K_r \cdot d = \mu \cdot N_{Sd} + \frac{N_{Sd}}{R} \cdot d \rightarrow \text{maximum horizontal force}$$

$$K_r = \frac{N_{Sd}}{R} \rightarrow \text{restoring stiffness}$$

$$\mu \rightarrow \text{friction coefficient}$$

$$N_{Sd} \rightarrow \text{vertical load acting on the isolator}$$

$$R \rightarrow \text{equivalent radius of curvature}$$

$$d \rightarrow \text{displacement}$$

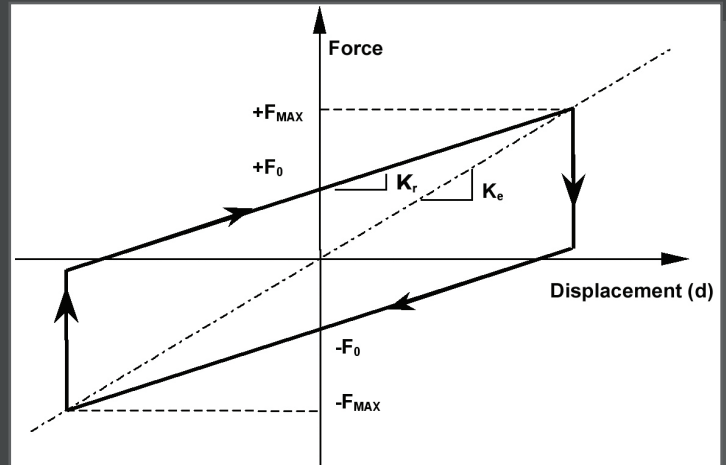

The vertical load N_{Sd} used to model the behaviour of the curved surface sliders under earthquake excitation is usually the quasi-permanent vertical load, i.e. the mass multiplied by the gravity acceleration, that is the average load acting on the isolator during the earthquake. Non-linear dynamic models that take into account the variation of vertical load during the earthquake are sometimes used.

The friction coefficient μ is a function of vertical load, as shown before. Usually it is calculated at the value of quasi-permanent load, according to the law $\mu(N_{Sd}/N_{Ed})$ given above.

In **FIP** series, the equivalent radius of curvature R coincides with the geometric radius of curvature of the primary sliding surface, while in **FIP-D** series R is approximately two times the geometric radius of curvature of each sliding surface.

When the Standard used for design of structures allows to model said non linear behaviour as a linear equivalent behaviour, the effective stiffness and the effective viscous damping can be calculated with the following formulae:

$$K_e = N_{Sd} \cdot \left(\frac{1}{R} + \frac{\mu}{d} \right) \quad \zeta_e = \frac{2}{\pi} \cdot \frac{1}{\frac{d}{\mu \cdot R} + 1}$$

It is worth noting that both the effective stiffness and the effective viscous damping depend on displacement; consequently, even when it is allowed to model the isolation system as linear equivalent, an iterative procedure should be applied, until the difference between the assumed and the calculated values of displacement becomes negligible.

Thanks to the dependence of the effective stiffness on vertical load, the center of mass and the center of stiffness of the isolation system coincide in plan.

The effective fundamental period, i.e. the period associated to the effective stiffness, of a structure isolated with curved surface sliders can be estimated as:

$$T_e = 2\pi \sqrt{\frac{1}{g \cdot \left(\frac{1}{R} + \frac{\mu}{d} \right)}}$$

The period associated to the restoring stiffness K_r is instead equivalent to that of a simple pendulum of length R :

$$T = 2\pi \sqrt{\frac{R}{g}}$$

DESIGN AND PRODUCTION CRITERIA

STANDARDS

The curved surface sliders (both series **FIP** and **FIP-D**) are usually designed according to the European Standard EN 15129:2009 *Anti-seismic devices*. On request, they can be designed to satisfy other standards or technical specifications.

DESIGN FEATURES

The standard **FIP-D** isolators whose geometrical and mechanical characteristics are listed in the enclosed tables, are designed for seven different values of maximum displacement, from 100 to 400 mm.

Such entity of displacement is understood to be the maximum displacement d_{Ed} according to EN 15129:2009.

For buildings and other structures other than bridges, d_{Ed} is given by the design displacement under seismic action d_{bd} , factored by the magnification factor γ_x as per Eurocode 8 (EN 1998-1:2005, § 10.3 (2)P).

For bridges, d_{Ed} coincides with d_{max} as defined in EN 1998-2:2009, § 7.6.2, i.e. is obtained by adding to the amplified design seismic displacement $\gamma_x d_{bd}$, the potential offset displacement due to the permanent actions, the long-term deformations of the superstructure, and the 50 % of the thermal action.

The vertical load N_{Ed} indicated in the tables is the maximum vertical load at ULS load combinations including the seismic action, or at any other load combination including horizontal displacement. The vertical load at zero horizontal displacement can be higher than N_{Ed} , and usually in r.c. structures depends on concrete strength.

The equivalent radius of curvature is fixed for each value of displacement; three different values have been used, 2.5 m for displacement 100 and 150 mm, 3.1 m for displacement 200 and 250 mm, and 3.7 m for displacement 300, 350 and 400 mm. It is recommended to use in a structure isolators with the same equivalent radius of curvature, in order to avoid differential vertical displacements associated to horizontal displacement.

A rotation value of 0.01 rad is assumed in the design, combined with maximum horizontal displacement d_{Ed} . At lower values of displacement, higher values of rotation are allowed.

FIP MEC's Technical Department may also design ad hoc curved surface sliders different from the standard ones to satisfy the Engineer's requirement, e.g. with different values of radius of curvature, displacement, vertical load, rotation, friction coefficient, or of the **FIP** series.

QUALITY CONTROL

FIP MEC's internal quality control system ensures the conformity of the product to the various requirements thus guaranteeing the quality both of materials and manufacturing processes.

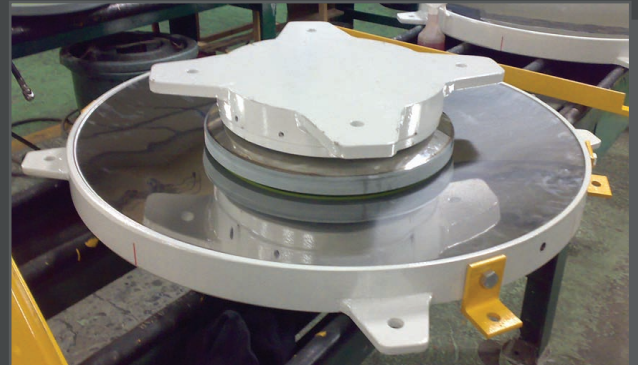

• Curved surface slider series **FIP** manufactured for Mary Bridge, Turkmenistan



• TURKMENISTAN - Mary Bridge



TYPE AND FACTORY PRODUCTION CONTROL TESTS

Both series **FIP** and **FIP-D** isolators have been tested at independent laboratories. In particular, full scale isolators of different sizes have been subjected to type tests according to the European Standard EN 15129, to the Italian Standard NTC 2008, and to other national Standards as well.

Furthermore, two **FIP-D** isolators were tested at the Seismic Response Modification Device Test Facility at the University of California at San Diego, USA, in order to verify their behaviour when submitted to a simultaneous bi-directional dynamic horizontal movement under vertical load. The isolators were subjected both to simultaneous sinusoidal movements along two primary axes (the so called "clover leaf" path as per EN 15129) and to a bi-directional time-history of horizontal displacement which reproduces the effect of an actual earthquake.

The reliability of **FIP MEC's** technology has been confirmed by the above mentioned type tests, as well as by many factory production control tests performed both at independent laboratories and at **FIP MEC's** Test Laboratory according to EN 15129 and the Italian Standard NTC 2008. Furthermore, dynamic tests on entire buildings of the C.A.S.E. project in L'Aquila, isolated with **FIP-D** isolators, were carried out by the Italian Civil Defence.



• Type tests on a double concave curved surface slider at Eucentre Trees Laboratory in Pavia.

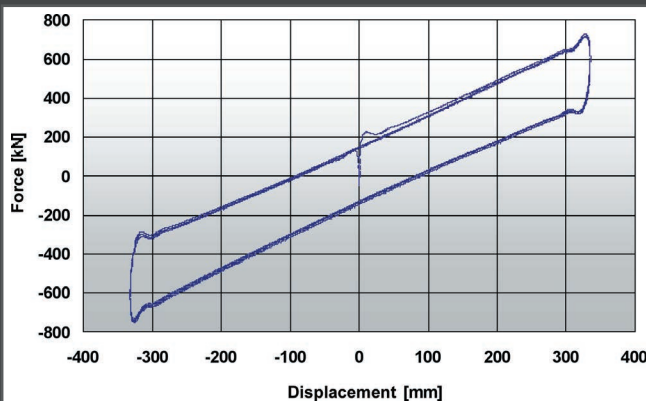

• Experimental hysteresis cycles of a double concave curved surface slider obtained in a test at constant velocity.



• Bi-directional type tests on a **FIP-D** isolator at the SRMD Test Facility at the University of California at San Diego, USA.

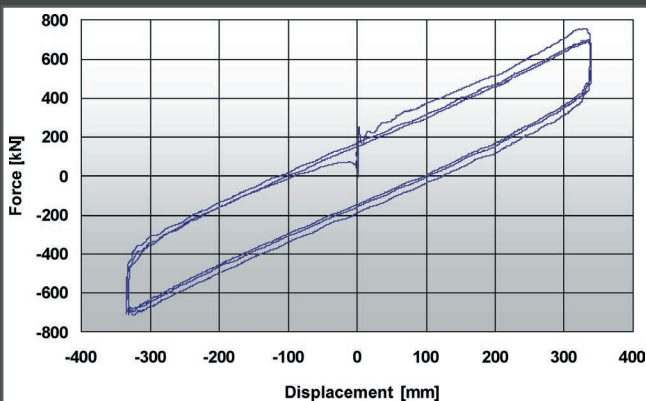

• Experimental hysteresis cycles of a double concave curved surface slider obtained in a sinusoidal test.



• Dynamic tests on a building of the C.A.S.E. project in L'Aquila (Italy) isolated with **FIP-D** devices.

DESIGN AND PRODUCTION CRITERIA

ANCHORING SYSTEMS

The curved surface sliders are fixed on to the structure by means of mechanical anchoring systems providing 100 % of the horizontal load transfer (despite the European Standard EN 15219:2009 allows that only 75 % of the horizontal load is supported by mechanical anchorages when the minimum vertical load on the isolators during the seismic action has been determined by non-linear dynamic analysis).

INSTALLATION

The typical installation procedure of an isolator anchored on its upper and lower side to reinforced cast-in-situ concrete structures, comprises the following phases:

- casting of the substructure up to a level lower than the isolator itself by a few centimeters, leaving holes for the anchor dowels with a diameter at least twice that of the same;
- positioning the isolator at the design level and leveling its base horizontally;
- construction of a formwork slightly larger than the isolator and approximately 1 cm higher than its lower edge;
- grouting (epoxy mortar or shrink free cementitious mortar) to a suggested thickness between 2 and 5 cm;
- screwing of the upper dowels to the isolator (if not already affixed);
- setting the upper formwork adapting it tightly against the isolator upper plate;
- positioning the superstructure reinforcement followed by concrete casting;
- following the hardening of the concrete, and in any case before the structure starts to be utilized, remove the transportation brackets (usually yellow) unscrewing the screws; re-tight all screw in their respective threaded holes in order to ensure the maximum anti-corrosion protection of the holes.

It is recommended to pay attention to protect the sliding surfaces of the isolators during the pouring of concrete. Should the sliding surfaces get accidentally dirty during installation, they shall be cleaned as soon as possible.

FIRE RESISTANCE

Curved surface sliders are characterised by intrinsic fire resistance, usually higher than 240 minutes, when installed in reinforced concrete structures, i.e. when the exposure to fire is only through lateral surface. However, replacement of the entire isolator that has been subjected to fire or at least of some parts of it (e.g. the sliding material and the stainless steel) could be necessary.

For curved surface sliders installed in steel structures, a passive fire protection system is recommended for the isolators as well as for the structural elements.



COMBINATION OF DEVICES

Curved surface sliders can be combined with other anti-seismic devices, to obtain special performance, useful in particular in bridge applications.

For example, they can be combined with shock transmission units for application on mobile piers of a bridge; the shock transmission units allow the slow movements due to the variations of temperature without transmitting a significant horizontal force to the pier, while under an earthquake the shock transmission units become stiff and the curved surface slider is activated, thus dissipating energy and ensuring the re-centring according to its force vs. displacement curve. This behaviour can be important in order to reduce the horizontal force transmitted to the pier under service conditions.



• FIP-D isolator combined with shock transmission units.

MARKS

The curved surface sliders or double concave curved surface sliders are classified by the mark **FIP** or **FIP-D**, respectively, followed by a letter and 3 numbers. The letter identifies the friction coefficient (L: low friction – M: medium friction), the first number is a conventional number, the second number represents the total displacement in millimeters and the third number (in brackets) stands for the equivalent curvature radius in millimeters.

Example:

FIP-D L 1200/600 (3700)

double concave curved surface slider that permits ± 300 mm horizontal displacement in all directions, with an equivalent curvature radius of 3700 mm and using low friction sliding material.



• TURKMENISTAN - Avaza Bridge



**BRIDGE
BEARINGS**

**ANTI-SEISMIC
DEVICES**

**EXPANSION
JOINTS**

**FITTINGS
FOR TUNNEL**

**NOISE
BARRIERS**

**DAMPING
SYSTEMS**

FIPMEC

FIP MEC S.r.l.
Via Scapacchiò, 41 | 35030 Selvazzano Dentro (PD) Italy
Tel : +39 049 822 5511 | Reg.Imprese PD | C.F. e P.IVA 01049070251
info@fipmec.it | PECfipmec@legalmail.it